



## Comparative analysis of the life cycle of evacuation pipes between classics and recycled for the sanitation in public buildings

**Autor:** Tomás García Martín

**Institución:** Universidad Camilo José Cela

**Otros autores:** Ricardo Díaz Martín (Universidad San Pablo CEU); Esperanza Batuecas Fernández (Universidad San Pablo CEU); F. J. Pérez Trujillo (Universidad Complutense de Madrid); Carlos Mayo del Río (Universidad Complutense de Madrid)

## Resumen

Through this communication is intended to realize the benefits that entails the use of materials made by recycled plastics in pipes of sanitation for the building in front of the same, for the same purpose, but whose origin is the initial obtained from virgin raw materials will be assessed the capacity of the line manufactured with recycled products aimed at the evacuation waters in buildings by substituting the preparation from virgin raw material with a view to achieving sustainable development through the comparison between environmental impacts with the technique of life-cycle analysis (LCA). The use of PVC materials-R (Poly Vinyl Chloride Recycling) from the recycling of various commercial products is going to allow the omission of a number of processes involved in the preparation of the final product as well as the exploitation through the recovery of a type of waste whose period of degradation seems very long and undesirable. The data of environmental pollution caused by the employment of the PVC pipes have been analyzed and incorporated into the inventory phase through the use of the software SimaPro8, thanks to this sight is the appropriateness of the use of recycled materials in the manufacturing process of this type of lines avoiding the reissue of polluting compounds in the atmosphere to the generation of new raw materials for the manufacture of the pipes and the environmental impact that brings with it the whole process.

**Palabras clave:** recycled PVC, drain pipes, Life Cycle Analysis, Extrusion

## 1.- Introduction:

The siftings Poli Vinyl Chloride are recyclable, in most cases, once removed and subjected to cleaning is subjected to a milling treatment. Subsequently, and regardless of their previous application can be reused if they are subjected to a new treatment. Vinyl is the only polymer composite that through its recycling could be rewritten and engage in new applications, which is not the case in the polyolefins recycled that they could not engage in different applications to the original.

The PVC is derived from common salt and the oil they were subjected to a process of electrolysis in the case of sodium chloride to obtain molecular chlorine and the second to a cracker for the obtaining of the monomer, ethylene, according to the process is shown in Fig.1.

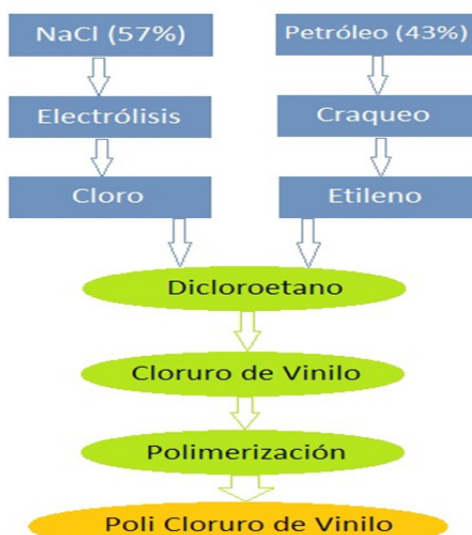
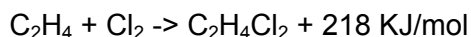

Fig.1 Obtaining PVC process

Chemical reactions and energy balance that involved in the production process of the PVC resin are the following:

- Chlorination Process:



- Oxychlorination Process :

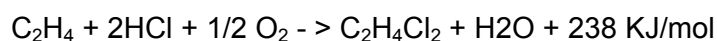

- Cracking Process:

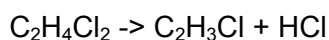

The overall reaction is the following:

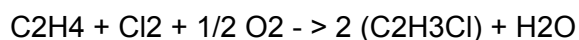

The traditional manufacturing of PVC piping is performed by the method of extrusion through which is part of a compound, previously formulated with virgin raw materials such as PVC resin as the main component,  $Ca(CO_3)$  and a stabilizer that tend to be organometallic salts compounds of Ba, Cd and Zn, carboxylates have and mercapturos organicestannosus compounds and combinations of Ca and Zn stearates by a mixing process at high temperature and under later to a process of melting and gelling occurs in machinery adapted to the process. The stabilizers are the only component of the mixture which maintains its reactivity during the life of the final product. Then comes to the ward said of extrusion and molding the outgoing semi-solid mixture extruder for the final product, line.

From here there is a second option for the manufacture of this type of pipes and it is through the use of recycled materials in the same nature and similar properties that are subject to a processing of laundering where impurities are removed from other types of compounds with different characteristics to the PVC and can be another type of polymers with different physical properties to the thermoplastic object of study and that they can be separated by a difference density between them. Subsequently, there is a mechanical handling, crushing, in order to reduce the particle size while maintaining the homogeneity in its size and favoring the fusion uniform during its processing in the extruder.

A second option, not always referred to, consists in the superreduction of particles size of recycled product through a post-process the crushing consisting of the micronization that allows you to obtain a micron particle size that will allow a reformulation of the recycled thermoplastic with new compounds, which in most cases it is inorganic charges, and stabilizers that are aid process to proceed to your mix to high temperature and obtain the compound that was subsequently ; to obtain the final product.

Any of the above steps leads us to the same product but with differences in the processed by varying the number of steps until its entry into the extruder and thus the costs of development.

The recycled material used for the manufacture of pipes comes from the processing of a series of end products that have suffered the processes outlined above and that from them you get one new final products that as we shall see later go to affect significantly in the reduction of  $CO_2$  emissions due to the different processes necessary to obtain the final product. This type of process is known as "Grave to Gate " because the end products that reach their end of life are recovered for processing and generation of new products.

In view of the importance for the existing society, in the transport of the water, you can deduct the PVC contribution in sustainable development, which depends on the balance between needs and social, economic and environmental goals.

Through this article you will proceed to analysis of environmental life-cycle of the two type of PVC piping for evacuation, with an initial raw materials and another with recycled material from different sources, in particular, residual line, and remnants of PVC window factory defective and withdrawal of buildings, in a comparative way and as a convenience in its application in future applications for the building.

The recycled material option for the manufacture of pipes as decision to sustainable development, is performed by scientific basis for comparison of different environmental indicators such as the damage and its grouping categories by taking into account the environmental risks to human health, ecosystem quality and resource consumption.<sup>1</sup>

During the analytical process are taken into account the by-products that come from compound generated from the formulation for obtaining the final product such as chlorine, included in the PVC resin, calcium and zinc in the stabilizers and waxes poliolefinics existing aid in the process. The most controversial of them all is the chlorine due to the resulting fumes during the obtaining the raw materials and the processing of PVC2 and may consist of a threat to health.

In our case we have proceeded to develop the final product from recycled PVC 100% without the use of original raw material, i.e. it prevents the initial step of obtaining raw materials in the petrochemical industry , avoiding the emissions generated during the process of obtaining, achieving a line with physical characteristics similar to the line manufactured from raw materials.

It is important to take into consideration the origin of the recycled PVC is used for the production of the recycled line because, depending on the origin will be required the inclusion or not of stabilizing what would entail the contribution of the compounds that provide the same.

To know which of the two types of line is the most respectful with the environment have been collecting the data corresponding to the inputs and outputs of all of the processes involved in the materials that comprise them through the analysis of inventory through the SIMAPRO8 software life cycle analysis, while respecting the principles of eco-design integrated into the ISO 14006 (Fig.2) on the basis of this is selected the most suitable product for the time to reduce to the maximum the environmental impact of the product.

---

<sup>1</sup> Granados, A. J. and Peterson, P. J. "Hazardous Waste Indicators for National Decision Makers". Journal of Environmental Management. 1999, 55, 4, 249-263.

<sup>2</sup> Lin, S. J. and Chang, Y. F. "Linkage effects and Environmental impacts from Oil Consumption Industries in Taiwan". Journal of Environmental Management. 1997.

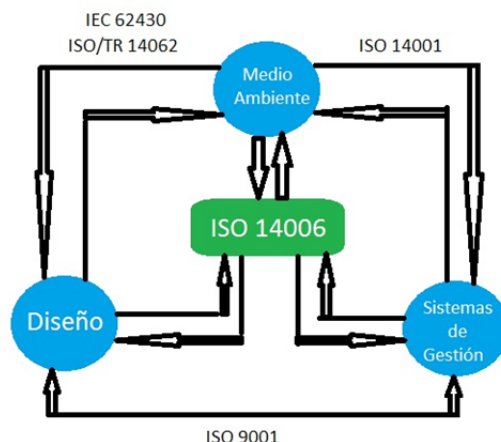

Fig.2: interrelationship of ISO 14006

Once you have made all the phases will proceed to a comparative analysis of both types of line from the data obtained.

## 2.- Experimental:

To carry out the experimental portion of this study has been used an industrial plant located in the southern area of Madrid (Spain) with all necessary machinery for its study that is listed below:

- Mill "EUROTECNO" brand with grid of 8 mm.
- A micronizer "GRUBER" brand with grid of 1 mm.
- Mixer 500 liters "Caccia" brand.
- Twin Screw Extruder parallel 120 "INDUSTRIE GENERALI WERE DOWN" brand.
- Several peripherals such as bath of vacuum, haul-off, and planetary saw.

The headpipe of the extruder was adapted for the manufacture of pipe of 110 mm outside diameter and 3.2 mm in thickness, using the rows corresponding to these dimensions.

- **Extruder Preparation:**

Initially, in the extruder, are selected operation process temperatures taking into account the different areas of the body of plasticizing (liner and spindles) Fig.3 and headpipe that contains the working row to achieve the desired diameter and thickness of the selected line from 3 155 °C, in the first zone and increased gradually to a value of 10 °C for the rest of the areas except in the header whose temperature needed to be adapted to facilitate the departure of the plastic in a smooth fashion.

<sup>3</sup>Source: <http://tecnologiadelosplasticos.blogspot.com.es/2011/03/extrusion-de-materiales-plasticos.html>

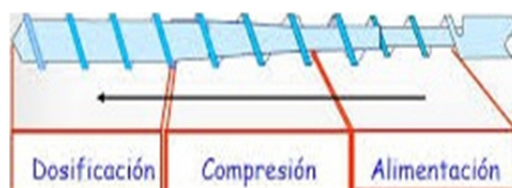

Fig.3: Area in Plasticizing Extruder

- **Material Preparation:**

Depending of material we'll describe the working formulation for the two types of line to the mixtures used in the study are the following:

Traditional Formula (Under Rule): In this starting from virgin raw materials depending on amounts presented in the table in the Fig.4.

PVC Formula-R1: By this, we start with recycled PVC, crushed that we incorporate only the dye to stain the molten mixture before forming depending on quantity listed in the table below (Tabla.1).

PVC Formula-R2: is part of recycled PVC, crushed and with a subsequent micronization treatment recombination according to its corresponding amounts in Tabla.1.

Once added the different compounds in the mixer, is applicable to the hot mixture to achieve the homogenization of the same by obtaining a compound that was subsequently transformed into the extruder. The mixing process is conducted with the formulations in the Table.1.

FORMULA	Mixing Process	PVC(kg)	Ca(CO <sub>3</sub> ) (Kg)	Shelfmark: Est. Ca-Zn carried out on variable surface charge (Kg)	Ac.Stearic acid(kg)	Dye(kg)	PVC- R
<b>Traditional</b>	If	100	15	2.5	0.25	0.05	-
<b>PVC-R1</b>	Not	-	-	-	-	0.05	100
<b>PVC-R2</b>	If	-	25	2.5	0.25	0.05	100

Table 1. Formulations used in the study

You selected a mixture of temperature of 110 °C, reached the same stopped the process and vacuum in a cooler with the order of thermally stabilized. The mixture was then added to the extruder through feed hopper and began the manufacture of the piping of the features described above.



*Fig.4. Mixing and homogenizing equipment*

The process for particle reduction size from PVC-R2 formulation was carried out in micronizer equipment up to a grain size of 0.7 mm. The equipment used is shown in Fig.5.



*Fig.5. Micronised Equipment*

The entire treatment process of PVC from landfill can be summarized by following diagram Fig.6

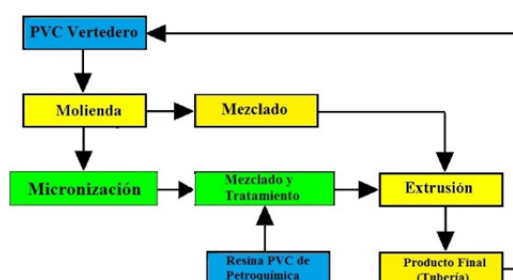

*Fig.6: Recycling process diagram*

Using the ACV will be the comparison of the three formulations for their evaluation from an environmental point of view and conclude the advisability of the use of one of them to the detriment of the other two.



### 3.- Considerations:

First and for a correct application from ISO 14044 defines the different life cycle stages for each of the compositions<sup>4</sup> and that is reflected in the Fig.7

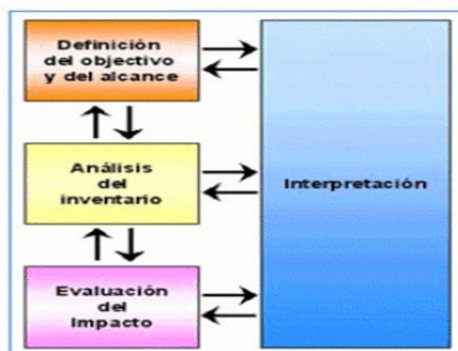

Fig.7: The General Structure LCA

Have been taken into account stages of obtaining raw materials and manufacture taking into account the damage caused during the stages of acquisition of compounds, processing, manufacturing, and management like waste. The analysis has centered on understanding the quantities, compositions and characteristics of used compounds in each formulations for the manufacture of the line.

To carry out the inventory stage and get a comparison between the lines developed with each formulation, has been taken as a functional unit 1 pipe (3 meters in length) and 3.2 mm thickness by obtaining a weight of 4.97 Kg. what has led to the development of the following quantitative table ( Table2):

FORMULA	PVC resin(Kg.)	CaCO <sub>3</sub> (Kg.)	Ca - Zn (Kg.)	CH <sub>3</sub> (CH <sub>2</sub> ) <sub>16</sub> COOH (Kg.)	Fe <sub>2</sub> O <sub>3</sub> (Kg.)	PVC-Recycling (Kg.)
Traditional	4.08	0.75	0.12	0,012	0.0025	-
PVC-R1	-	-	-	-	0.0025	4,967
PVC-R2	-	1.25	0,125	0.0125	0.0025	3.58

Table 2: Amount of components expressed in kg. /Tube of 3 meters

<sup>4</sup> ISO (2006) ISO 14044: Environmental management-life cycle assessment-requirements and guidelines. International Standard Organization, Geneva

#### 4.- Results of Assessment Impact:

After performing the LCA comparative are known categories with the largest impacts, as well as which of the products has greater contribution to them.

The results were presented below. (Table 3)

IMPACT CATEGORY	UNIT	PVC	PVC R1	PVC R2
Rather than abiotic depletion	Kg Sb eq	1.08 E-06	1.38 E-06	1.88 E-06
Rather than abiotic depletion (fossil fuels)	MJ	1.95E+02	-1.81E+02	-1.17E+02
Global warming (GWP100a)	Kg CO <sub>2</sub> eq	8.68 E+00	E+00 -6,47	E+00 -3,73
Ozone layer depletion (ODP)	CFC-11 kg eq	1.05 E-07	2.74 E-07	3.06 E-07
Human toxicity	Kg 1.4 -DB eq	9.76 E-01	1.16 E-02	3.44 E-01
Viernheim Photochemical	Kg C <sub>2</sub> H <sub>4</sub> eq	1.56 E-03	E-04 -6,86	E-04 -2,08
Acidification	Kg SO <sub>2</sub> eq	4.37 E-02	E-03 -2,67	2.22 E-02
Speed Eutrophication	Kg PO <sub>4</sub> --- eq	9.14 E-03	1.65 E-03	7.18 E-03

Table 3: Results obtained in LCA by impact category.

There was a characterization and standardization through by CML IA baseline method 5

It can be observed that in most categories, the impact associated with the non-recycled product is greater than the other.

Anyway, depending on the impact that is being analyzed it is found that the recycled products may have greater contributions than the product itself without recycling.

The abiotic depletion categories, carbon footprint, human toxicity, photochemical oxidation acidification and eutrophication proved to be more harmful to the environment in the case of the conventional PVC compared to the cases of recycled Vinyl.

In turn, in the majority of categories is the PVC R1 which gets better results. It's cause of simpler process, with less power consumption and fewer additives than the PVC case R2.

- **Characterization**

It's phase where are quantified and added, through factors of characterization data of the inventory in the different impacts categories. (Fig.8)

<sup>5</sup> De Guinée, J. B. ; Gorree, M. ; Heijungs, R. ; Huppes, G. ; Kleijn, R. ; De Koning, A.; Oers, L. van; Wegener Sleeswijk, A. ; Suh, S. ; Udo de Haes , H. A. ; De Bruijn, H.; Duin, R. van; Huijbregts, M. A. J. Handbook on life cycle assessment. Operational guide to the ISO standards. I: LCA in perspective. IIa: Guide. IIb: Operational annex. III: Scientific background. Kluwer Academic Publishers, ISBN 1-4020 -0228-9, Dordrecht, 2002, 692 pp.

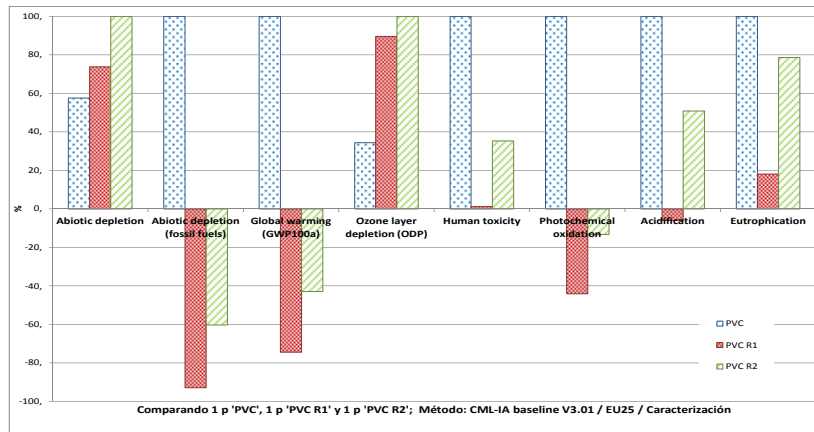

Fig. 8: Characterization by CML method

- **Normalization**

It's phase where we evaluate the relative contribution of each of the different types of impact. <sup>6</sup>

It is in this step where you can check which of all the categories analyzed is the highest with respect to the other.

Thus, in this case, it obtained the graph below. (Fig.9)

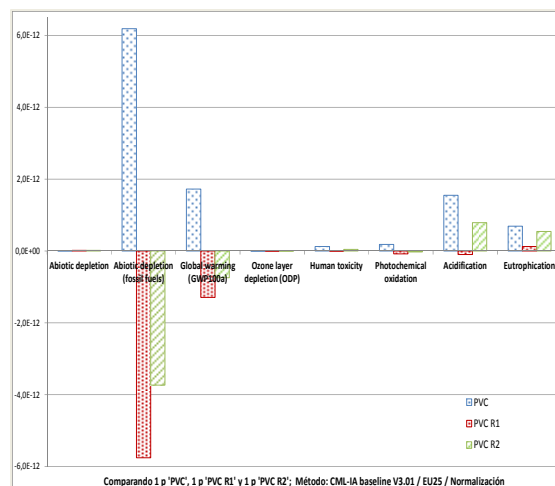

Fig. 9: Standardization through CML method

**Analysis of more prominent categories.**

- **Global warming potential. Carbon Footprint GWP 100a.**

The carbon footprint expresses emissions of CO<sub>2</sub> and other greenhouse gases. It is measured in kg of CO<sub>2</sub> equivalent.

The carbon footprint is higher in the conventional PVC, proving the PVC-R1 and PVC-R2 contributions not only best but negative to this impact category. This is so because the elements are considered recycled products avoided. That is to say, the use of PVC Recycling prevents the production of conventional PVC, with the environmental benefits that entails.

<sup>6</sup> Huijbregts, M. A. J. ; Breedveld L. ; Huppes, G. ; De Koning, A. ; Van Oers, L. ; Suh, S. 2003. Normalisation figures for environmental life-cycle assessment: The Netherlands (1997/1998), Western Europe (1995) and the World (1990 and 1995). Journal of Cleaner Production 11 (7): 737-748.

- Exhaustion of abiotic resources (fossil fuels)

Determines the use of fossil fuels. It is measured in energy units, MJ.

In the LCA has been obtained that the PVC this is the impact category more damaging to the environment. However, recycled PVC is, either PVC-R1 or PVC-R2, not only decreases the impact but that becomes negative.

Thus, the biggest environmental problem in this analysis is solved by replacing the PVC products by conventional PVC recycling. This will be achieved with a large progress in the care of the environment.

- Water footprint.

Part of the CML method, we wanted to complete the analysis by getting the water footprint.

The water footprint represents the depletion of water resources and their impact is quantified in m<sup>3</sup> of water.

The calculation method used was Hoekstra et al 2012.<sup>7</sup>

We assessed the water footprint of the products in order to obtain the following results (Fig.10)

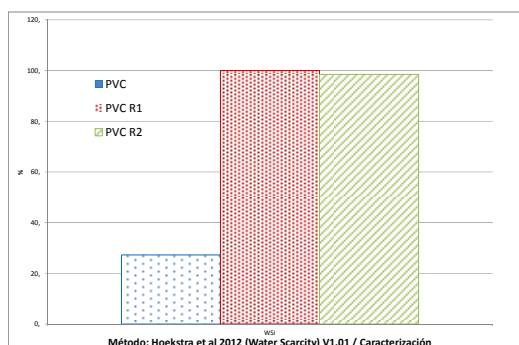

Fig. 10: Hoekstra method for water footprint evaluation

Unit	PVC	PVC R1	PVC R2
M <sup>3</sup>	5.65	20.72	20.42

The analysis determines that the same is greatest in the recycled products that in the conventional vinyl. This is due to recycle a material requires a post-processing (removing, cleaning, etc.), which requires water in quantities greater than those of end-of-life alternative methods of handling. Send to landfill or incinerate a product requires little processing, therefore small amounts of water. With this it is concluded that recycle a product carries a water footprint associated superior to another processing as it could be the incineration of the same.

<sup>7</sup> Hoekstra AY, Mekonnen MM, Chapagain AK, Mathews RE, Richter BD (2012) Global Monthly Water Scarcity: Blue Water Footprints versus Blue Water Availability. PLoS ONE 7 (2): E32688. doi:10.1371/journal.pone.0032688

### **5.- Conclusions:**

Recycled plastics are increasingly common in construction world.

They are compounds very attractive from an environmental point of view, since residues can be used to make these products by providing an important added value.

As regards its characteristics, the recycled products (PVC-R1 and PVC-R2), show the same behavior that the product generated by PVC formulated in conventional manner. With the recycling at no time will lose quality or properties. This is what is called supraciclaje, i.e. match or improve on the properties of the initial product.

The versatility in formulations of thermoset polymer matrix would add that inert inorganic waste, for example, partially blocked the combustion by improving their behavior to fire; becoming resistant.

Most of the existing recycling is in reality infraciclaje where the quality of a material is reduced over time. In addition, the recycled products often have a purpose for which they were not designed. Not still this case it is to be presented.

It is concluded that by encouraging a change in the way that we will design things; everything must be designed so that once used doesn't end up in what would be termed a tomb, i.e. a landfill, but that is part of the start of the next productive chain. This is what is called "cradle to cradle".

Thus, the optimum will be the lines, after the completion of its useful life, they become part of another new improved line; in no case to landfill.

## 6.- References:

1. Granados, A. J. and Peterson, P. J. "Hazardous Waste Indicators for National Decision Makers". *Journal of Environmental Management*. 1999, 55, 4, 249-263
2. Lin, S. J. and Chang, Y. F. "Linkage effects and environmental impacts from Oil Consumption Industries in Taiwan". *Journal of Environmental Management*. 1997.
3. Source:<http://tecnologiadelosplasticos.blogspot.com.es/2011/03/extrusion-de-materiales-plasticos.html>
4. ISO (2006) ISO 14044: Environmental management-life cycle assessment-requirements and guidelines. International Standard Organization, Geneva
5. De Guinée, J. B. ; Gorree, M. ; Heijungs, R. ; Huppes, G. ; Kleijn, R. ; De Koning, A.; Oers, L. van; Wegener Sleeswijk, A. ; Suh, S. ; Udo de Haes , H. A. ; De Bruijn, H.; Duin, R. van; Huijbregts, M. A. J. Handbook on life cycle assessment. Operational guide to the ISO standards. I: LCA in perspective. IIa: Guide. IIb: Operational annex. III: Scientific background. Kluwer Academic Publishers, ISBN 1-4020 -0228-9, Dordrecht, 2002, 692 pp.
6. Huijbregts, M. A. J. ; Breedveld L. ; Huppes, G. ; De Koning, A. ; Van Oers, L. ; Suh, S. 2003. Normalisation figures for environmental life-cycle assessment: The Netherlands (1997/1998), Western Europe (1995) and the World (1990 and 1995). *Journal of Cleaner Production* 11 (7): 737-748.
7. Hoekstra AY, Mekonnen MM, Chapagain AK, Mathews RE, Richter BD (2012) Global Monthly Water Scarcity: Blue Water Footprints versus Blue Water Availability. *PLoS ONE* 7 (2): E32688. doi:10.1371 /journal.pone.0032688